

DEVELOPMENT OF A VANED TYPE NOVEL AIR TURBINE

Bharat Raj Singh¹ and Onkar Singh²

1. Professor and Dean, Department of Mechanical Engineering, Sagar Institute of Technology & Management, Barabanki-225001, UP, India. E-mail: brsinghko@yahoo.com Tel: +91-5248-220001 Mob: +91-94150-25825

2. Professor, Department of Mechanical Engineering, Harcourt Butler Technological Institute, Nawabganj, Kanpur-208002, UP, India. E-Mail: onkpar@rediffmail.com Tel: +91-512-2534001 Mob: +91-9415114011

ABSTRACT

In view of the ongoing search for alternate energy sources the compressed air has been considered as a potential working fluid for generating shaft work. In this paper the details of developments of a very small capacity air turbine with vaned type rotor have been presented. It is seen that this air turbine could be successfully used as a prime mover to run light vehicles / motor bikes having small capacity inbuilt compressed air storage tank. The proposed air turbine has been developed and is in the process of testing. Some results based on its testing have been presented here.

Keywords: Compressed air, shaft work, air turbine, emission, zero pollution, dual inlet & exit

1. INTRODUCTION

About 100 years ago, the major thrust of energy shifted from recent solar to fossil fuel (hydrocarbons). Technological advances have led to a greater use of hydrocarbon fuels, making civilization vulnerable to decreases in supply. The current study (Alekkett & Campbell - 2004) made in the year 2004, predicts that if the oil is consumed at the current rates, then by 2020, we will be consuming 80% of the entire available resources. This necessitates the search for alternative of oil as energy source or preserving it by tapping some other alternatives such as Non-conventional energy like battery operated vehicles, wind mills, photocells etc. and to convert their output into mechanical energy.

Presently because of better developments & availability of facilities, urban population is raising use of vehicles rapidly,

causing air pollution and greenhouse gases that come from vehicle emissions. This is the primary motivation behind developing alternative transportation technologies that do not rely on combustion of fossil fuels. Consumer acceptance of a replacement transportation technology, however, is highly dependent on the new vehicle sticker price, operating expenses, reliability, and convenience of use. The worldwide researches are also going on for other alternatives such as use of Hydrogen Fuel Cell (Honton-2004, Rose & Vincent-2004), which is presently very costly, use of Bio-Diesel (Singh & Singh-2006a) or use of compressed air for Vehicle engines (Singh & Singh-2006b).

Thus, it is advantageous for the energy storage system of a Zero Pollution Vehicle (ZPV) to have low initial cost, be quickly and economically recharged, and to provide driving performance comparable to that of conventional automobiles. In addition, the most desirable technological solutions will eliminate the release of automotive combustion products in areas of poor air quality, while also reducing the net amount of pollutants released to the environment as a consequence of their implementation. Careful consideration of the overall environmental impact of a particular ZPV technology and the corresponding costs of necessary infrastructure developments are required to evaluate the ability of any new transportation system to meet the goals of society. Currently, the battery-powered electric vehicles and hydrogen cell vehicles (Knowlen et al. - 1998) are the only commercially available technology that can meet ZPV standards; however, these vehicles have not captured

market & sold well due to their limited range, no proper facilities for recharge, and high initial cost. All of these issues have given birth to the technology of compressed air energy storage and its utilization in transport vehicles and other domestic utilities.

The “Guy Negre”, a French technologist and inventor has developed 4-cylinder compressed air engine, which can run the vehicle at 60-80 miles per hour speed without tail pipe emission. So far about 52- patents (Guy & Negre-2004) were made during 1998 to 2006 and recently MDI and Tata Motors entered into an agreement to develop such vehicles in commercial use. These highly compressed air energy storage systems (Rocha -2005) with 300 psi, which can be filled within 15-20 minutes, may remain the dominant technology in the electric and hydrogen cell vehicle market.

In this paper, we are going to explore the use of compressed air storage energy for running varied type novel air turbine and different aspects for improving its efficiency of shaft works.

2.0 USES OF COMPRESSED AIR AS AN ALTERNATIVE

India is developing country and per capita income of average person is very low to meet out the minimum requirement of person. Maximum population of country is still living in villages where transport is still either bi-cycle or motorbike. Current hike of fossil fuel are increasing tremendously up to 30-40 % every year. With this pace by 2010 prices may go double than what is today and by 2030-40, it may touch to Rs.1000 per litre. A time will come when common person would not be able to purchase fuel to run the motorbike. It is not only due to rate of increase of vehicles in India, but it is a worldwide problem due to the 80 % of fossil fuel being consumed in transport with increasing mobility of persons and transportation of daily consumable materials through road transport. Thus, it is the need of the day to explore possibility of alternatives for fossil fuel to make environment free from emission & make children healthy.

Since the last two decades lot of researches are being made to tap down air freely available in atmosphere and compressing it for storage in cylinders for its further use. This compressed air can be used to run combustion engine with mixture of gas and air getting fired at compression stroke at TDC. Compressed air helps for fire stroke when ignition takes place.

Thus efficiency of IC engine gets improved and without running all four stroke cycle it runs on two stroke cycles. But air engines so far developed are basically running on hybrid such as compressed air and gases and are not 100% zero pollution.

2.1 Availability

Air is natural source and available freely in atmosphere, which can be stored after compressing it to desired pressure such as 90-350 psi. This is the only source, which can be stored at very high pressure and can be retained without any loss after lapse or with passage of time. Compressed air can drive many domestic appliances such as vacuum cleaner, mixers, pumps, electric generator when electric power fails instead of using inverter to have clumsy arrangements of battery etc.

2.2 Influences on Environment and Ecology

The light vehicles presently running on fossil fuel releases tail pipe emission and creates imbalances to ecology, ultimately hazardous to public health. Compressed air as an alternate for running light vehicles using air turbine will have no ill effect on ecology and reduce the health hazards.

2.3 Sustainability, Economics and Advantages

Compressed air is most sustainable. It has no volatility or temperature or much weather effect. Once compressed air is stored through compressor, it will be available at any time without any loss of pressure. Thus sustainability of compressed air is much better compared to other available alternate of fossil fuel. Battery needs constant maintenance even for charging & discharging cycle. Hydrogen Cell (Rose et al. -2004) is very costly due to its storage problems. Wind Mills (ABI Research-2004), Photo Cells also need some storage devices may be of high bank capacitors or batteries, which will need constant and recurring expenditures on its upkeep.

3.0 MODEL OF AIR TURBINE

Present objective is to develop an air engine using air turbine with output of 6.85 HP to 7.50 HP at 5500 to 7500 rpm, which will be suitable for a motorbike. Various steps involved in the development of engine are as given separately. A cylinder of compressed air is proposed to have minimum capacity of storing air for requirement of 30 min running at initial stage and maximum pressure of 200-300 psi. The

Air Turbine with dual inlet and exhaust has been taken into consideration to produce high rpm to match 7500-8000 rpm. Compressed air storage cylinder is designed so that it produces constant pressure for minimum variation of torque at low volume of compressed air.

A spring loaded baffle is installed into the cylinder to regulate the constant air pressure. The Air Turbine is designed with spring-loaded vanes to maintain regular contact with elliptical bore, to produce optimum torque (Faglsang-2004, Selig-2004, Reddy Gorla-2005, Schreck & Robinson-2004). Above air turbine is being designed to meet out the all-minimum parameters of motorbike to have efficient and fossil fuel free running.

3.1 Steps involved in developments of Novel Air Turbine

- Created the 2-d technical drawing and fabricate the 3-d models of parts.
- Designed and made the compressed air storage cylinder, springs for the vanes etc.
- Updated the test protocol and test setup as desired and assembled the motor and test setup.
- Run the performance test and recorded data and analyzed the data and preparing the final setup.

3.2 Single Inlet & Exhaust model for Air Turbine

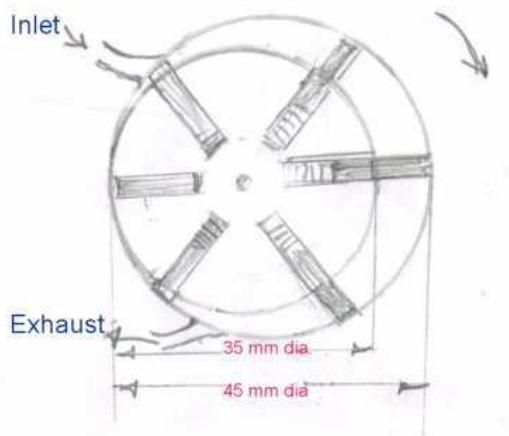

Fig. 1 Compressed Air Turbine –Concept & Cycle

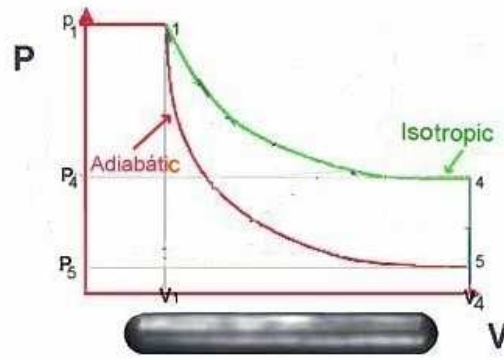

Fig.2 Isotropic cycle for Air Turbine

3.3 Design considerations for Air Turbine

3.3.1 Empirical Requirements

Required Air pressure: 60-150 psi (assumed)

*Speed: 3000 rpm

*Torque: 9.6-10 Nm

P-V Ratio: 4 / 5

Note: - *Data based on Performance of commercially available motorbike (7.2 HP)

3.3.2 Principle

For novel air turbine the high pressure air is the driving force at ambient temperature. The impulse and dynamic action of high pressure are responsible for the shaft work from air turbine.

It is reverse process of vane type air compressor. Considering the isotropic expansion of air entering the Air Motor having n vanes, theoretical work is given as under: -

$$w = n \left(\frac{\gamma}{\gamma - 1} \right) p_1 v_1 \left\{ \left(\frac{p_4}{p_1} \right)^{\frac{\gamma - 1}{\gamma}} - 1 \right\} - n (p_4 - p_5) v_4 \quad \rightarrow (1)$$

Where W = Theoretical Work done,

p_1 & v_1 are Pressure & Velocity respectively at which air strike the Turbine,

p_4 & v_4 are Pressure & Velocity, respectively at which maximum expansion of air takes place,

p_5 is the Pressure at which Turbine releases the air to atmosphere.

In order to meet the requirements of initial design of cylinder, rotor and vanes considered are given below: -



Fig. 3 Compressed Air Turbine –Working Model



Fig. 4 Compressed Air Turbine –Model under Test

3.3.3 Results and Discussions

From the theoretical calculations, results obtained at different pressure and rpm relations between “Air Consumption & Speed” as well as “Torque & Speed” are drawn. Here it is evident that better speed can be achieved at lower Consumption of Air, if the negative forces acting due to higher difference in pressure between P_4 to P_5 are almost eliminated.

From equation \rightarrow (1)

$$w = n \left(\frac{\gamma}{\gamma-1} \right) p_1 v_1 \left\{ \left(\frac{p_4}{p_1} \right)^{\frac{\gamma-1}{\gamma}} - 1 \right\} - n (p_4 - p_5) v_4$$

$$\text{Let } \frac{\gamma-1}{\gamma} = k \text{ (constant)}$$

$$w = \frac{n \cdot p_1 \cdot v_1}{k} \left\{ \left(p_4^k \cdot p_1^{-k} \right) - 1 \right\} - n (p_4 - p_5) v_4 \quad \rightarrow (2)$$

Applying Lagrange’s Multiplier, the Optimum value of Shaft-Work will be obtained when:-

$$\frac{\partial w}{\partial v_4} = 0 \quad \rightarrow (3)$$

$$\frac{\partial w}{\partial p_4} = 0 \quad \rightarrow (4)$$

Applying Equation (3),

$$\frac{\partial w}{\partial v_4} = 0,$$

$$-n (p_4 - p_5) = 0$$

or

$$p_4 = p_5 \cong 1.0 \text{ Atm Pr or } 1.0132 \text{ bar} \rightarrow (5)$$

Applying Equation (4),

$$\frac{\partial w}{\partial p_4} = 0,$$

$$n \cdot \frac{p_1 \cdot v_1}{k} p_1^{-k} \cdot k \cdot p_4^{k-1} - n \cdot v_4 = 0$$

$$\text{or } n \cdot p_1^{1-k} \cdot v_1 \cdot p_4^{k-1} - n \cdot v_4 = 0$$

$$\text{Let } c = p_1^{1-k} \cdot v_1,$$

$$\text{then } n \cdot c \cdot p_4^{k-1} - n \cdot v_4 = 0$$

$$\text{Therefore } p_4 = \left(\frac{v_4}{c} \right)^{\frac{1}{k-1}} \quad \rightarrow (6)$$

From the above, it is clear that for optimal shaft work, p_4 has direct relation with v_4 , p_1 & v_1 , where $(p_1^{1-k} \cdot v_1)$ is taken as a constant,

$$p_4 = p_5 = 1 \text{ atm. pr.}$$

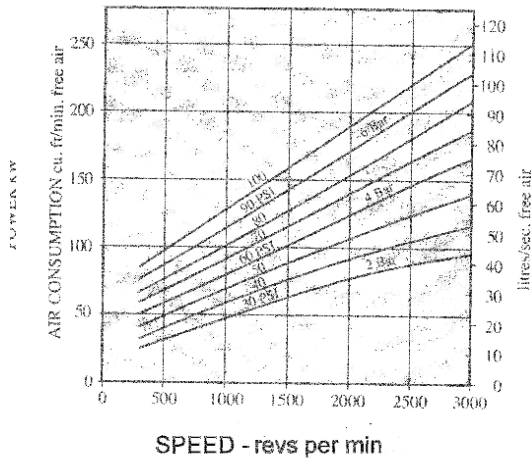

Graph-1 Air Consumption versus Speed

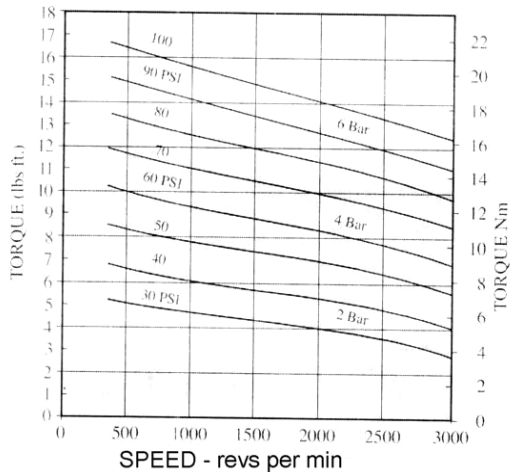

Graph-2 Torque versus Speed

3.3.4 Dual Inlet & Exhaust model for Air Turbine / Engine

Dual inlet & exhaust Air Turbine is under fabrication and concept is introduced as dual elliptical cylinder having spring loaded vanes as designed above wherein negative effect as indicated in Eq. (1) is almost reduced which enhances the shaft work and make the Turbine most efficient and novel in its functions.

When the exit compressed air pressure of first stage is fed into second stage inlet of Air Turbine, the expansion of residual compressed air is further expanded from V_4 to V_4' and pressure P_4 is substantially reduced to P_4' and closer to the P_5 (see Fig. 6). Looking to the Equation. (1), it is evident that if $P_4' \geq P_5$ the negative effect will almost vanish and shaft output would become optimum.

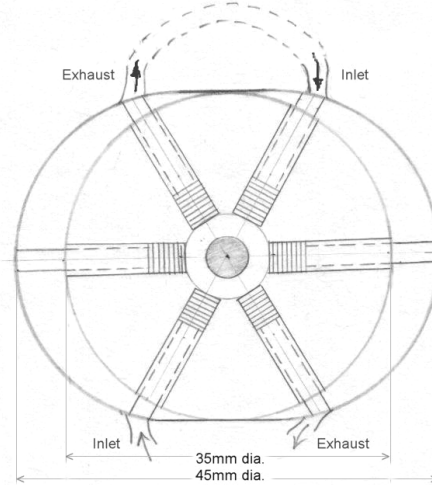

Fig.5 Dual inlet & exhaust Air Turbine Model

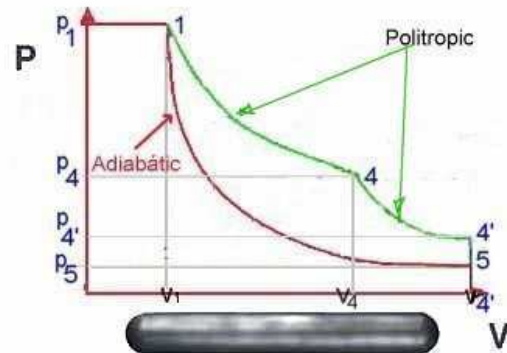

Fig.6 Dual inlet & exhaust Polytropic Curve

4.0 CONCLUSION

In view of the enormous potential of air as working fluid, an Air Turbine having dual inlet and exhaust is designed to run on compressed air. The compressed air is to be contained in a portable cylinder at 300-psi air pressure. This Air Turbine is under close test run and expected to be most efficient than the currently available one, as negative workforces are eliminated and ultimately it is going to be the best alternate to the fossil fuel driven prime-over / engine.

5.0 REFERENCES

- [1] ABI Research- March'16th 2004 - "Wind Turbines" – Market Wire, NY
- [2] Aleklett K. and Campbell C.J. - Feb.2004 - "The Peak and Decline of World Oil and Gas Production" – Oil Production.
- [3] Fuglsang P., Bak C., Gunna M. - ASME- Nov'2004 - "Design and verification of the Ris0-B1 Airfoil-family for Wind Turbines". Vol.126 pp 1002-1008.
- [4] Gorla Rama Subba Reddy- IJTJE - 2005- "Probabilistic Heat Transfer and Structural Analysis of Turbine Blade" - Vol. 22, pp 1- 11.
- [5] Guy and Negre Cyril - Tuesday 29th June '2004- "Compressed Air - The Most Sustainable Energy Carrier for Community Vehicles"– Speech in front of assembly at Kultur gathered for "Fuel Cells World"
- [6] Honton E. J. - US based inventor - April'2004- the Hydrogen Fuel Cell Car presented at 15th Annual US Conference & Hydrogen Expo, USA.
- [7] Knowlen C., Bruckner A. P., Mattick A.T., and Hertzberg A. -1998- Society of Automotive Engineers, Inc. - "High Efficiency Energy Conversion Systems for Liquid Nitrogen Automobiles"- AIAA 98-1898.
- [8] Rose Robert, William J. Vincent-February' 2004- "Fuel Cell Vehicle World Survey 2003"-Break through Technologies Institute, Washington, D.C.
- [9] Rocha Beau de (Otto) –25th Sept'2005 - Quasiturbine zero pollution cars using gasoline at Korea.
- [10] Schreck S. & Robinson M. – ASME- Nov' 2004 - "Tip Speed Ratio Influences on Rationally Augmented Boundary Layer Topology & Aerodynamic Force Generation" - Journal of Solar Energy Engg.-Vol.126 pp1025-1033.
- [11] Selig Michel S. -ASME-Nov'2004 - "Wind Tunnel Aerodynamics Tests of Six Airfoils for use on Small Wind Turbines".
- [12] Singh Onkar & Singh B.R. - October'13th -15th, 2006 – Bio-Fuel Vision-2015 -Proceedings of International Conference at Bikaner, India "Necessity & Potential for Bio-Diesel Use in India" Page 71.
- [13] Singh Onkar & Singh B.R. - 10th-11th June, 2006 – "Compressed air as an alternative to Fossil Fuel for Automobile Engines" International Conference at Lucknow, India- Proceedings pp 179-191.